



CB4 CARGO BARRIER

2020+ FORD PI UTILITY | SCA COMPLIANT

Installation Instructions



CB4 Cargo Barrier - 475-0067



CB4 Cargo Barrier with Poly Cover - 475-1337

SUGGESTED TOOLS:

- Ratchet
- 7/16" Socket
- 3/16" Hex Key Socket
- 5/32" Hex Key Socket
- 9/32" Socket or Phillips-head Screwdriver
- 13 mm Socket
- 18 mm Socket
- T55 mm Torx Bit Socket

HARDWARE BAG 475-1444

1. Bolt, .25-20x.50, CB, CZ, 5
2. Bolt, .25-20x.5, BHCS, Blk
3. Bolt, .25-20x1.25, BHCS, Blk
4. Bolt, .25-20x1.5, CB, CZ, 5
5. Nut, .25-20, HFN, Whiz-Lock, CZ
6. Cap, 1/4", Black, Press-On

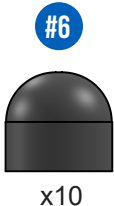
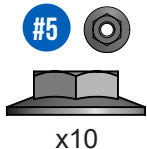
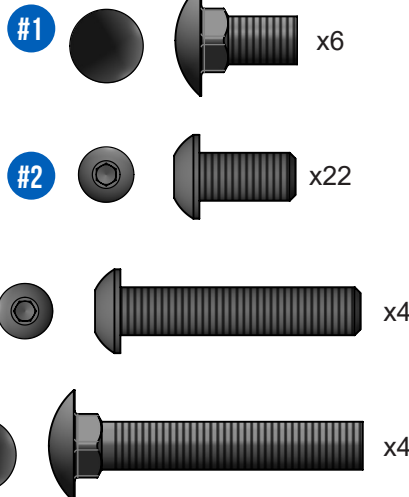

HARDWARE BAG 475-1445

7. Bolt, .25-20x.50, CB, CZ, 5
8. Nut, .25-20, HFN, Whiz-Lock, CZ
9. Cap, 1/4", Black, Press-On

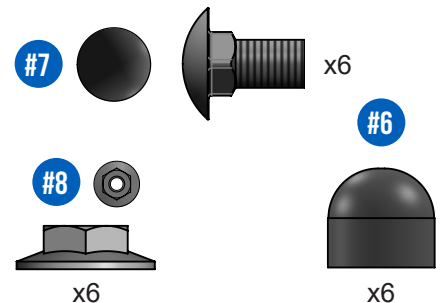

This hardware bag is for the 475-1337 CB4 Cargo Barrier with Poly Cover only.

Before beginning the installation, confirm that you have received all of the parts for your package.
Read the instructions completely before starting installation.

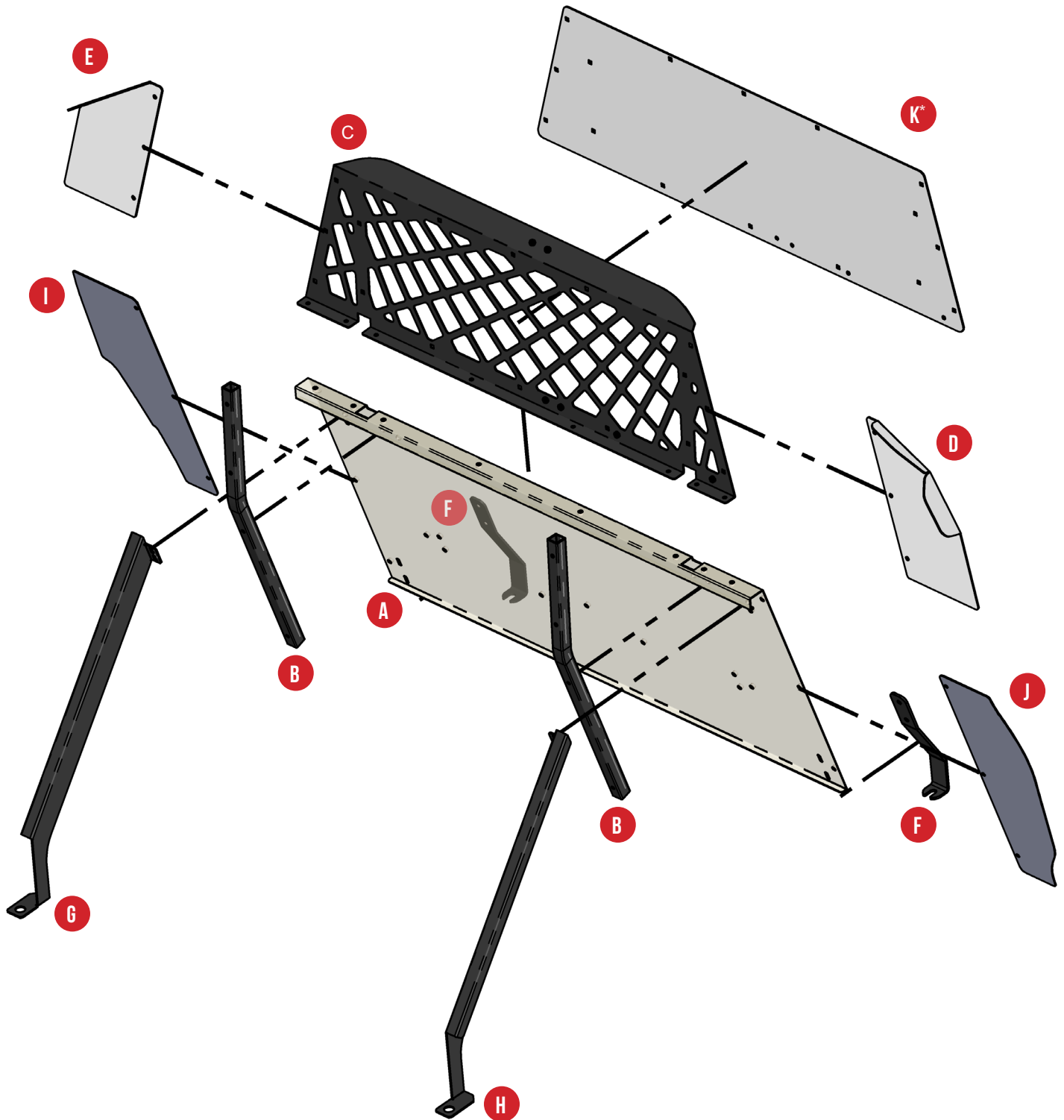

BILL OF MATERIAL

A. Panel, Lower, CB4, PIU 20+
B. Tube, Vertical, CB4, PIU 20+
C. Grid, Secure, CB4, PIU 20+
D. Wing, PS, CB4, Poly, PIU 20+

E. Wing, DS, CB4, Poly, PIU 20+
F. Foot, Lower, CB4, PIU 20+
G. Support, DS, CB4, PIU 20+
H. Support, PS, CB4, PIU 20+

I. Wing, DS, CB4, PIU 20+
J. Wing, PS, CB4, PIU 20+
K. Cover, Poly, CB4, SG, PIU 20+*
* 475-1337 only

* SEATS MUST REMAIN UPRIGHT DURING INSTALLATION

STEP 1

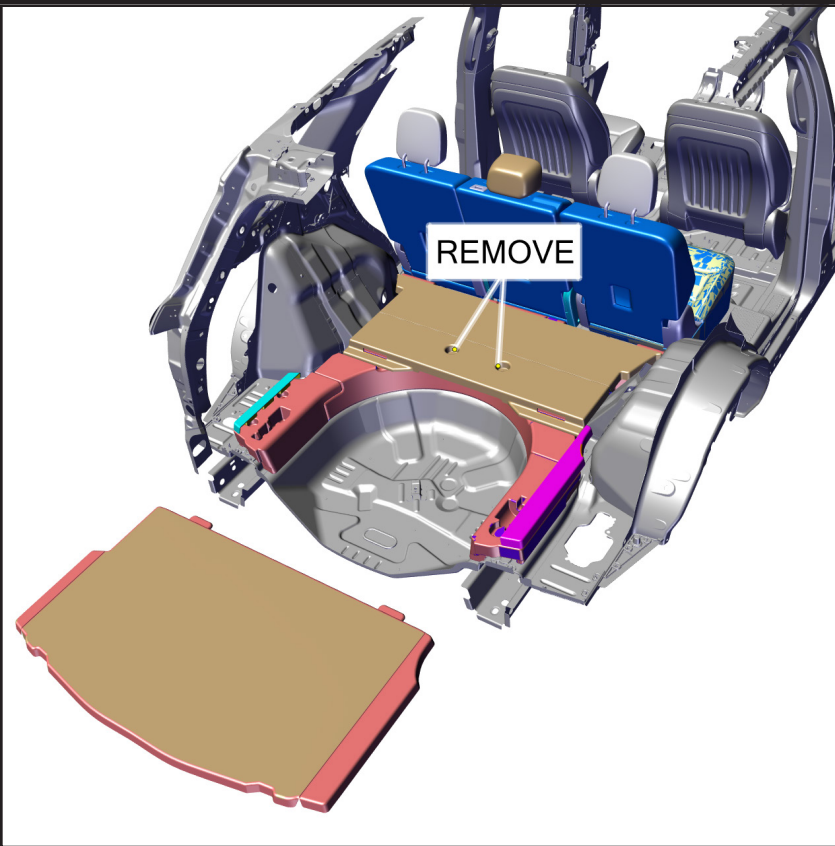

- Remove OEM flooring starting at the hatch. This portion can simply be pulled out.
- Remove the (2) OEM bolts to remove forward flooring and set aside for replacement.

STEP 2

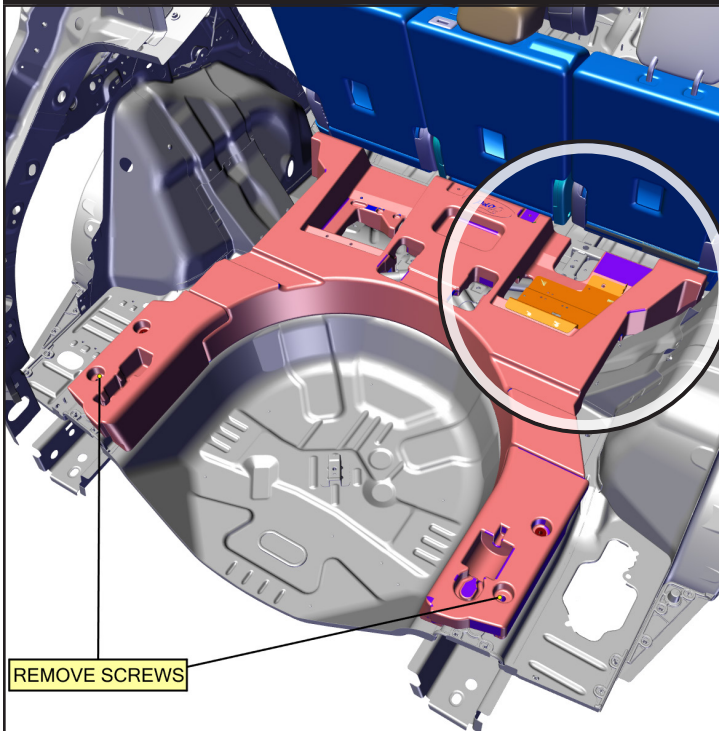

- Remove the (2) 8 mm OEM bolts holding the end pieces in place.
- Unclip the wire harness and remove the cover plate to remove the upper foam from the vehicle. Once Cargo Barrier is installed, this will be reinstalled into vehicle.
- Remove OEM solid foam core from cargo area in both sections.

STEP 3

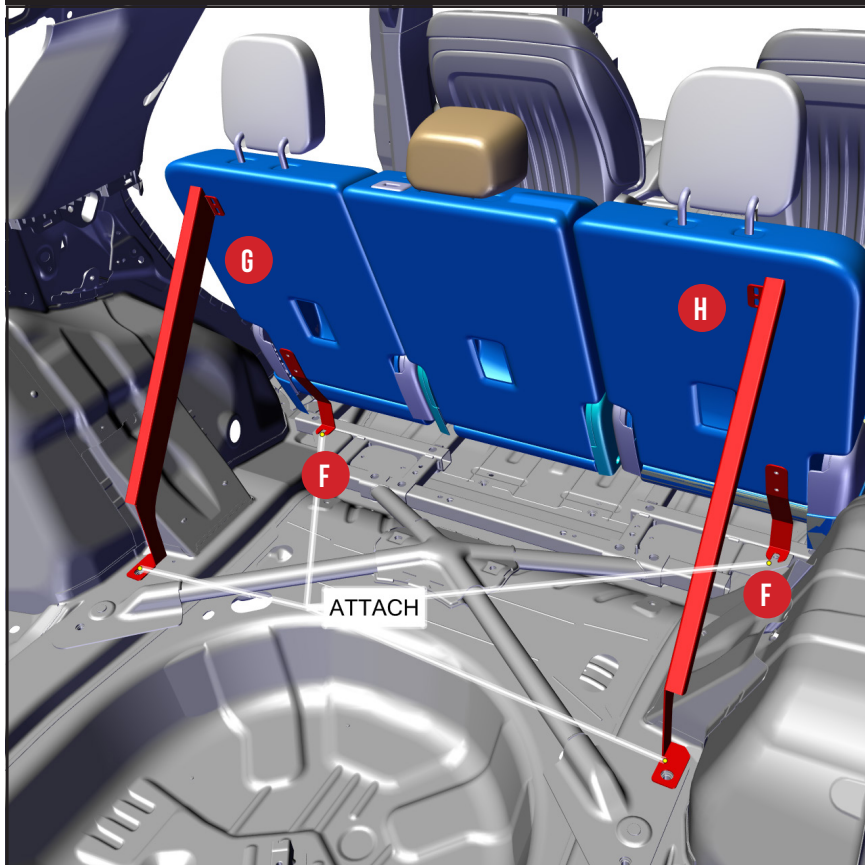

- Install the **G** and **H** supports to the OEM 13 mm rear seat bolts and (2) **F** feet into the vehicle by removing the OEM 18 mm bolts located on the lower rear cross brace.

STEP 4

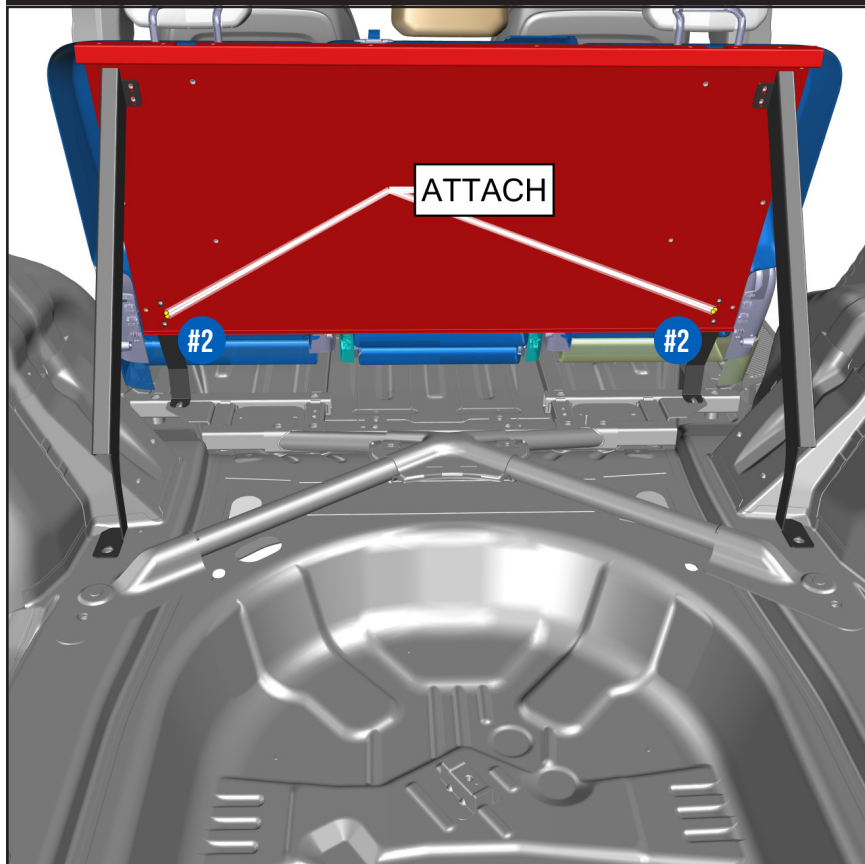

- Install the **A** panel through the rear of the vehicle.
- Attach the **A** panel to the previously installed **G** and **H** supports with (4) **#2** bolts. The (2) **F** feet will support the **A** panel.

* **DO NOT ATTACH YET.**

STEP 5

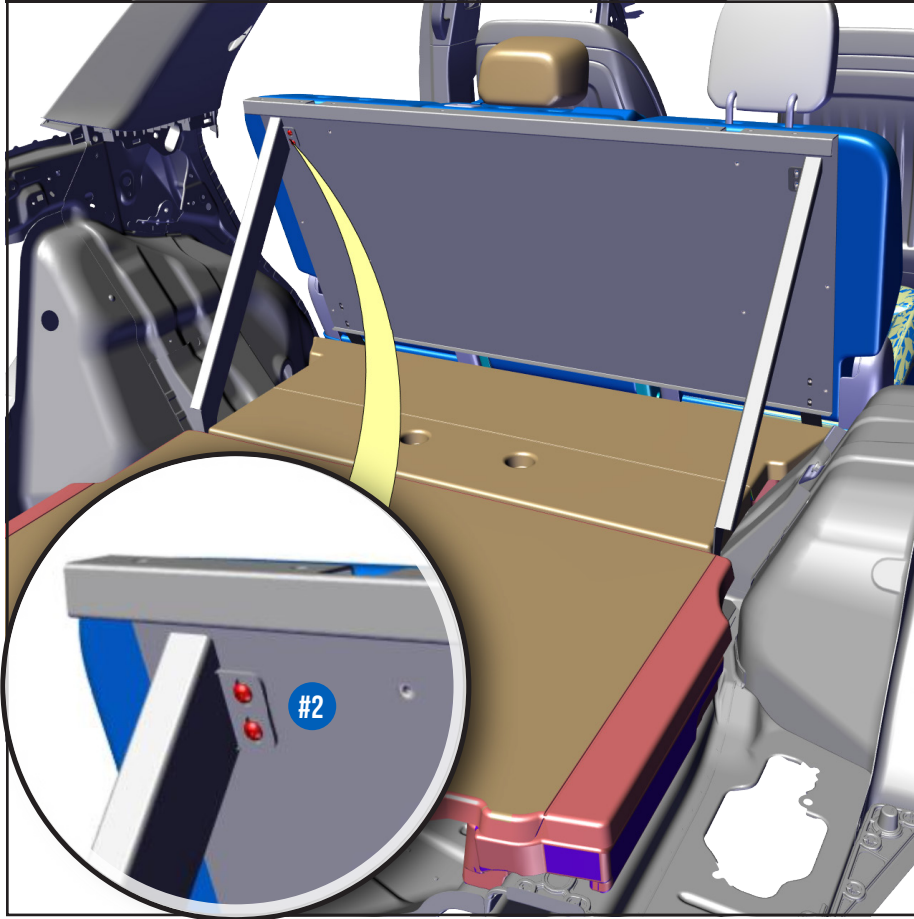

- Reinstall the OEM solid foam core and OEM flooring. Secure in place with previously removed (2) OEM bolts.
- * You can now attach the **G** and **H** supports to the **A** panel with (4) #2 bolts.

STEP 6

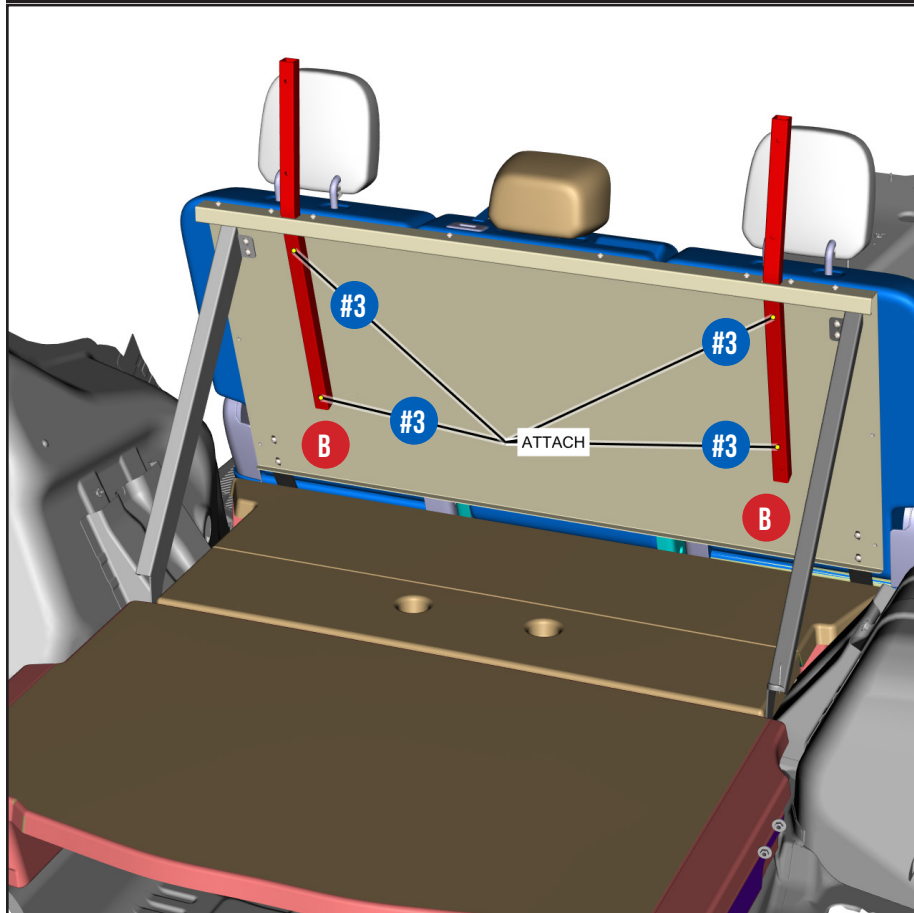

- Insert and secure the (2) **B** tubes to the **A** panel from cargo side.

STEP 7

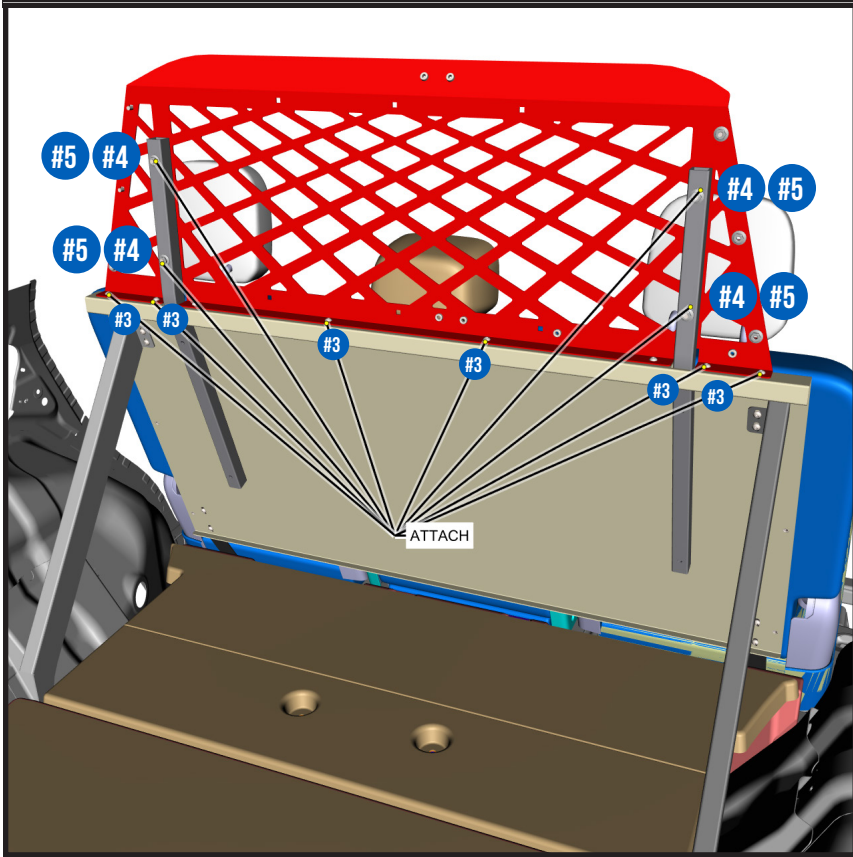

- From rear seat of vehicle, use (6) **#3** bolts to attach the **C** grid panel to the **A** panel and (4) **#4** bolts and (4) **#5** nuts to the **B** tubes.

STEP 8

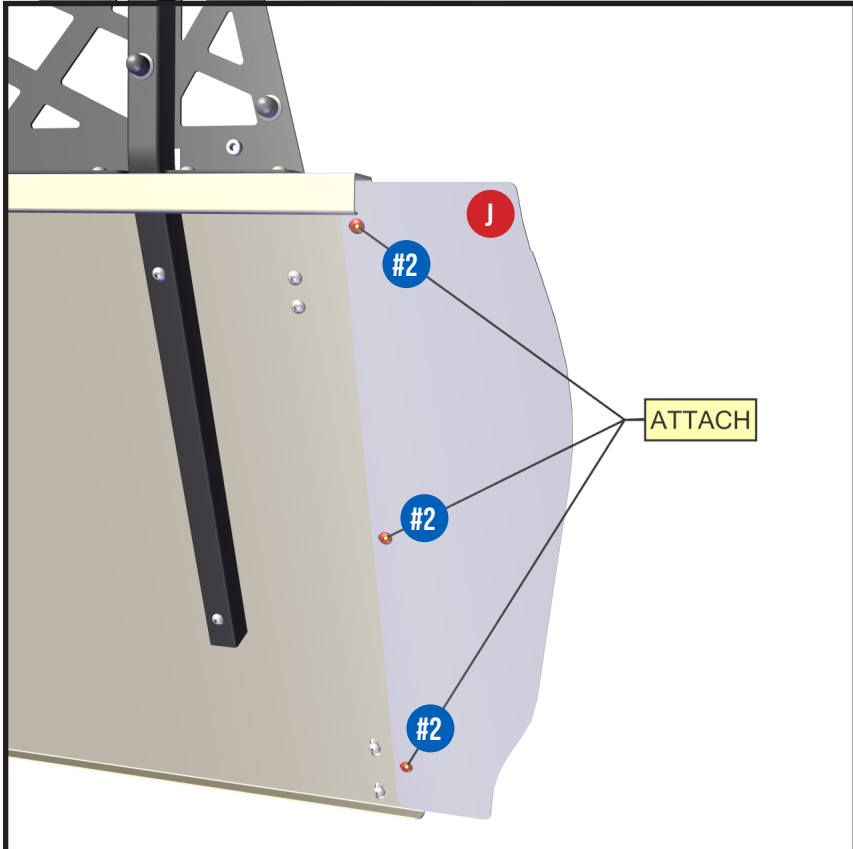

- Install the **I** and **J** lower wings with **#2** bolts to the rear side of the cargo barrier.

* For Poly Cover (475-1337),
installation instructions see below.

The instructions below only apply to the 475-1337 CB4 Cargo Barrier with Poly Cover.

STEP 9

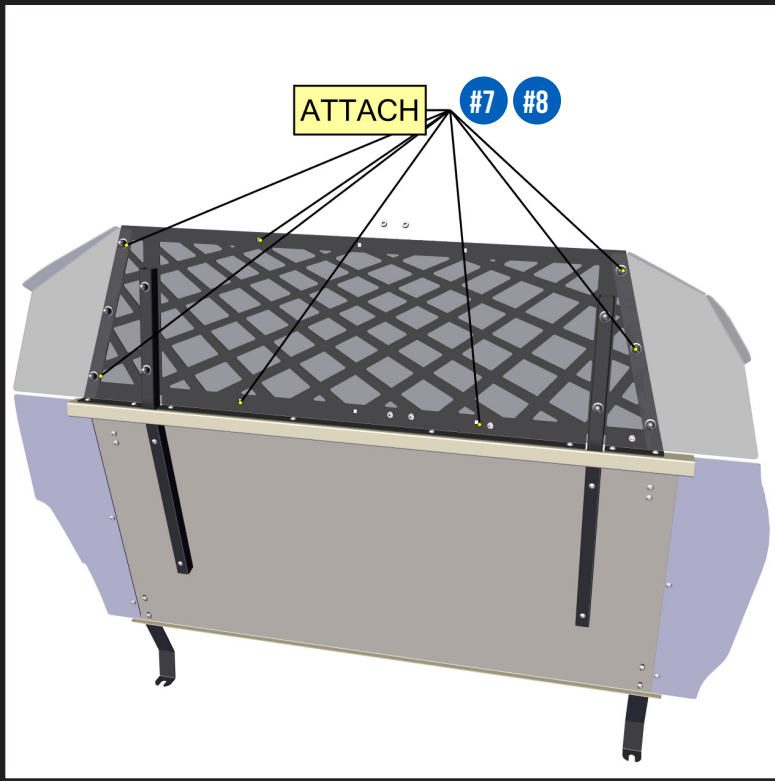

- From rear seat of vehicle, use (7) **#7** bolts and (7) **#8** nuts to attach the **K** poly cover to the front of the **C** secure grid and **B** tubes.

STEP 10

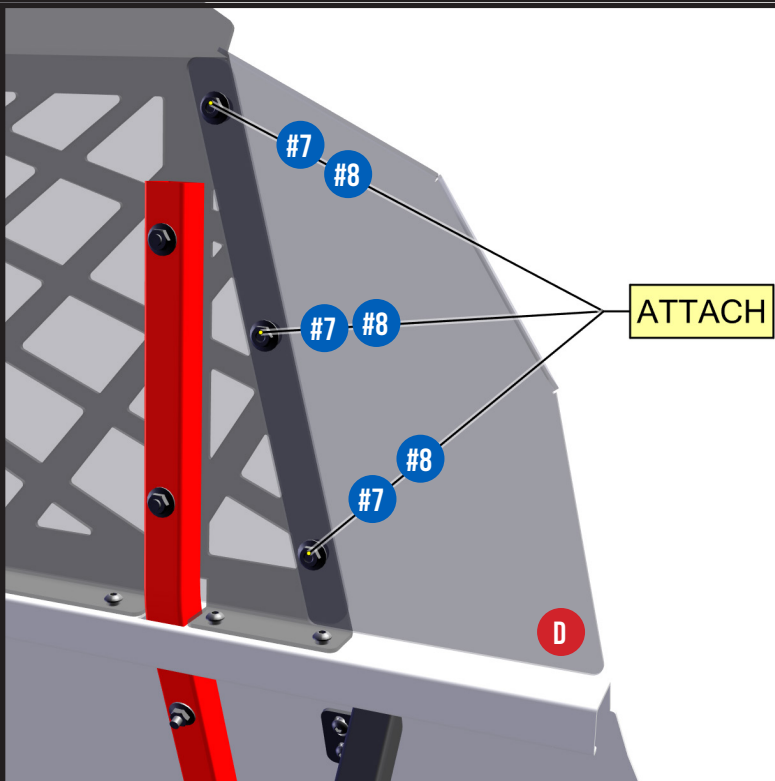

- Install the **E** and **D** upper wings through the rear of the vehicle. Secure with (3) **#7** bolts and **#8** nuts.

If you have questions or need further assistance please call Technical Support: 1.877.455.6886

405 WEST EASY STREET, ROGERS, AR 72756 • JOTTOPUBLICSAFETY.COM • 10/25

Jotto Desk™ is a patented product and Registered Trademark of Kiefer Sage™.
Specifications subject to change without notice.

050-0084-01